

# Tefal<sup>®</sup>

## ECO MASTER

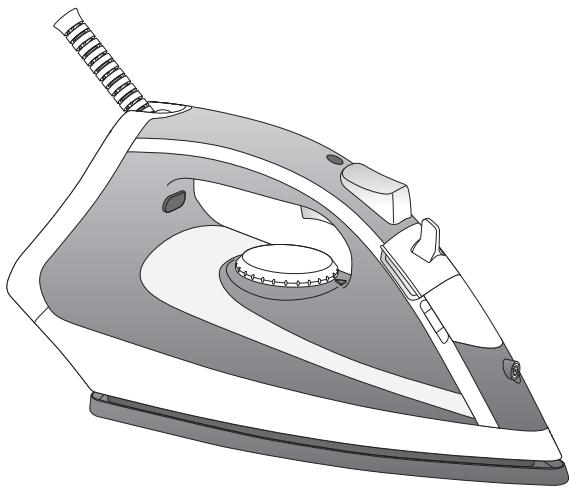

## INSTRUCTIONAL MANUAL

For further usage information

Please read carefully the «Safety and use instructions» booklet before first use

## For your safety

This appliance complies with the technical rules and standards for safety currently in force (Electromagnetic Compatibility, Low Voltage, Environment).

- **Please read these instructions carefully and keep them for future reference.**
- This appliance is not intended for use by persons (including children) with reduced physical, sensory or mental capabilities, or lack of experience and knowledge, unless they have been given supervision or instruction concerning use of the appliance by a person responsible for their safety.  
Children must be supervised to ensure that they do not play with the appliance.
- **Warning ! The voltage of your electrical installation must correspond to that of the iron (230V). Connecting to the wrong voltage may cause irreversible damage to the iron and will invalidate the guarantee.**
- This iron must always be plugged into an earthed socket. If using a mains extension lead, ensure that it is correctly rated (16A), with an earth connection.
- If the electrical cord becomes damaged, it must be immediately replaced by an Approved Service Centre to avoid any danger.
- The appliance should not be used if it has fallen, if it has obvious damage, if it leaks or has functional anomalies. Never dismantle your appliance : have it inspected by an Approved Service Centre, so as to avoid any danger.
- Never immerse your iron in water !
- Do not unplug your appliance by pulling on the cord. Always unplug your appliance: before filling or rinsing the reservoir, before cleaning it, after each use.
- Never leave the appliance unattended when it is connected to the mains. Before storing the appliance, once it is unplugged, please wait until it has cooled down(around 1 hour)
- Your appliance gives off steam, which may cause burns. Take extra care especially when you are ironing close to the edge or on a corner of your ironing board. Never direct the steam towards people or animals.
- Your iron should be used and placed on a flat, stable, heat-resistant surface. When you put your iron onto its iron rest, make sure that the surface on which you put it is flat and stable.
- This product has been designed for domestic and indoor use only. Any commercial use, inappropriate use or failure to comply with the instructions, the manufacturer accepts no responsibility and the guarantee will not apply.

## What water to use?

Your appliance has been designed to function with untreated tap water. However, it is necessary to operate the Self-Clean function regularly in order to eliminate hard water deposits from the steam chamber.

If your water is very hard (check with your local water authority), it is possible to mix untreated tap water with store-bought distilled or demineralised water in the following proportions :

- 50% tap water, - 50% distilled or demineralised water.

## Types of water not to use?

Heat concentrates the elements contained in water during evaporation. The types of water listed below contain organic waste or mineral elements that can cause spitting, brown staining, or premature wear of the appliance : water from clothes dryers, scented or softened water, water from refrigerators, batteries or air conditioners, pure distilled or demineralised water or rain water should not be used in your Tefal iron. Also do not use boiled, filtered or bottled water.

## Environment



### Environment protection first !

- ① Your appliance contains valuable materials which can be recovered or recycled.
- ➔ Leave it at a local civic waste collection point.

## If there is a problem?

PROBLEM	POSSIBLE CAUSES	SOLUTIONS
Brown water is dripping from the soleplate and soiling your clothes.	You are using chemical descaling products.	Do not put any descaling product into the water tank.
	You are not using the right water.	Perform a self-clean and consult the "What water to use?" section.
The soleplate is dirty or brown and may soil clothes.	The temperature is too high.	Clean the soleplate as indicated in the user guide Use a lower temperature.
Your iron produces little or no steam.	Your iron has limescale.	Clean the anti-limescale valve and perform a self-clean.
The soleplate is scratched or damaged.	You have positioned your iron flat on the metallic iron support. You have cleaned your soleplate with an abrasive cloth or steel wool.	Always place your iron in the support base Clean the soleplate as indicated in the user guide.
Your soleplate emits particles.	Limescale is starting to build up on your soleplate.	Perform a self-clean .
Water drips from the holes in the soleplate.	You are using steam while the iron is not hot enough.	Wait until the thermostat light goes out.

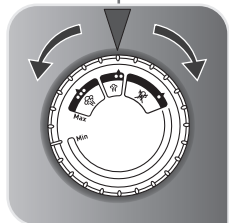
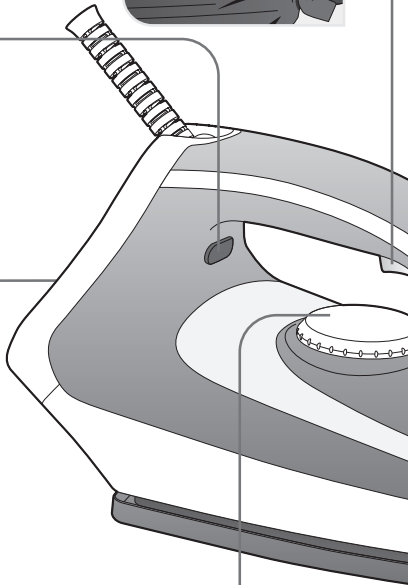
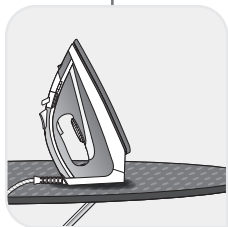
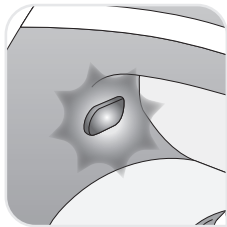
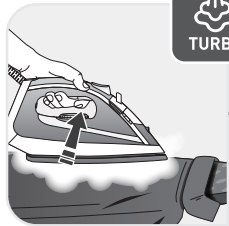

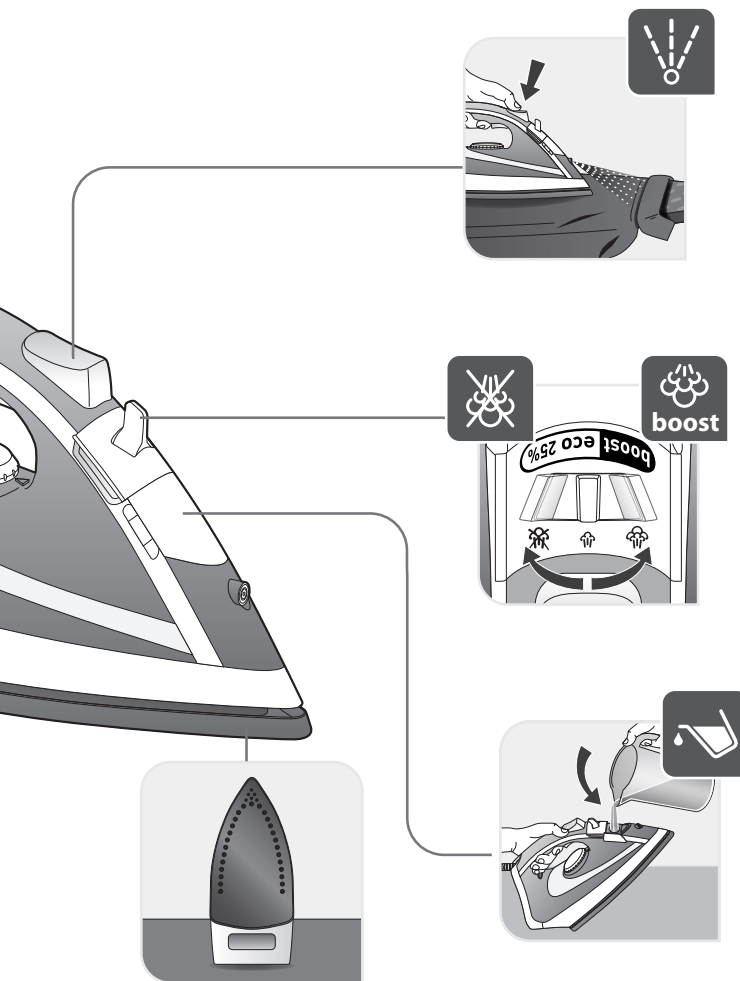

## FILLING THE TANK

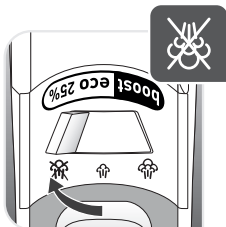

# STARTING THE APPLIANCE

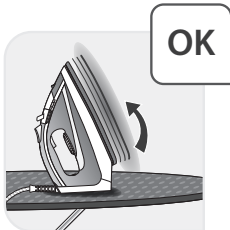
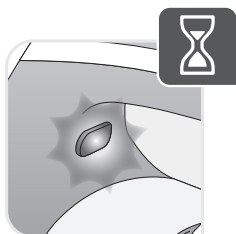
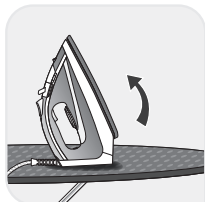
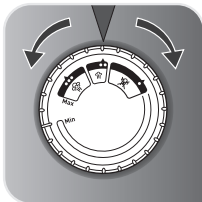
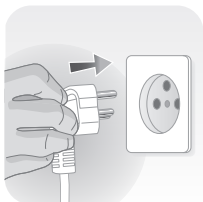
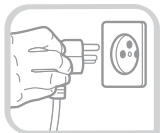

# STEAM SETTING

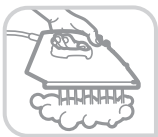



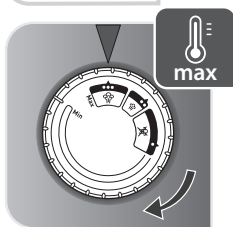
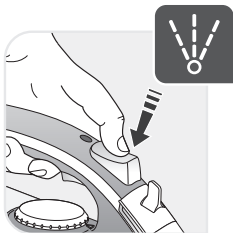

# SPRAY

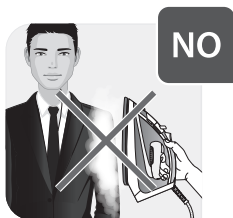
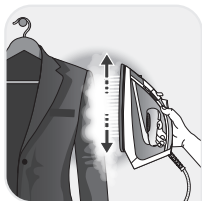
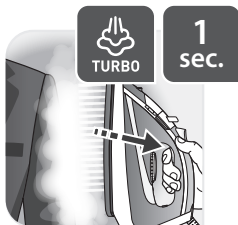
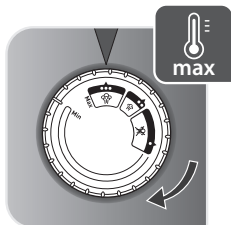
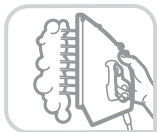

# VERTICAL STEAM

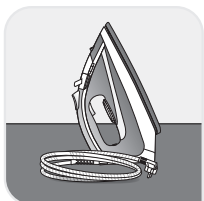
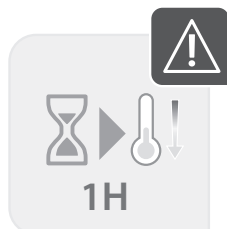
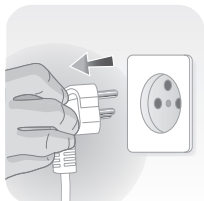
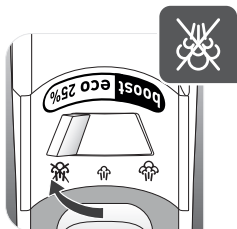

# SOLEPLATE CLEANING



# SELF CLEANING



1H



# OPERATING INSTRUCTIONS

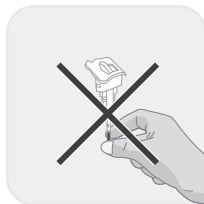
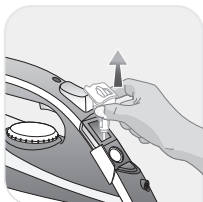
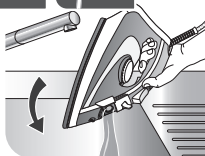

# OPERATING INSTRUCTIONS

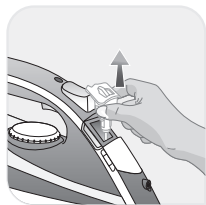
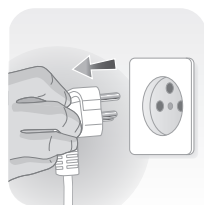
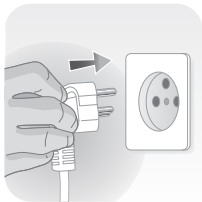

# OPERATING INSTRUCTIONS

